

BALL VALVES

KHY-2F-F-VIII/FEP/FEP

Lined ball valve with flanges, PN10, 16, 25

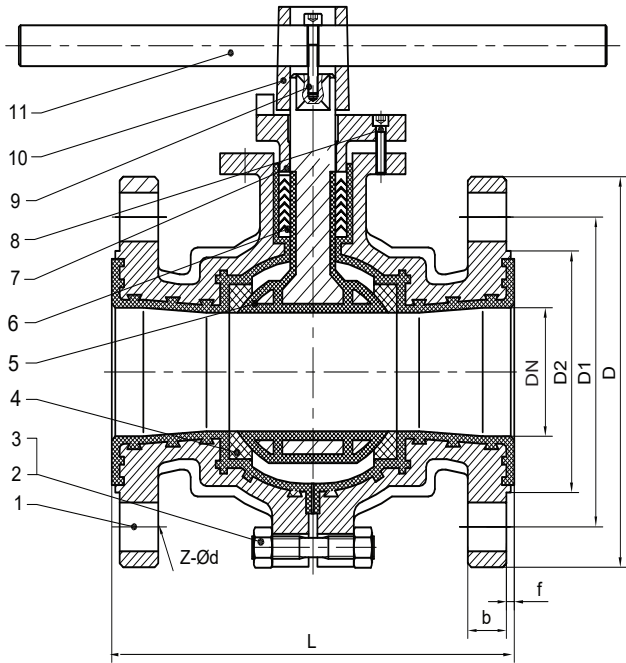

PARTS

No.	Part	Material		
1	Nut	A194 2H	A194 8	A194 8M
2	Lever	A216 WCB	A351 CF8 / A351 CF8M	A351 CF3 / A351 CF3M
3	Locating plate	25 # SS304		
4	Body bolt	A193 B7	A320 B8	A193 B8M
5	Gland	A216 WCB	A351 CF8 / A351 CF8M	A351 CF3 / A351 CF3M
6	Packing	PTFE		
7	Stuffing box	A216 WCB + lining	A351 CF8 7 A351 CF8M + lining	A351 CF3 / A351 CF3M + lining
8	Body bolt	A193 B7	A320 B8	A193 B8M
9	Body	A216 WCB + lining	A351 CF8 7 A351 CF8M + lining	A351 CF3 / A351 CF3M + lining
10	Seat	PTFE / RPTFE / PEEK		
11	Ball/stem	A216 WCB + lining	A351 CF8 7 A351 CF8M + lining	A351 CF3 / A351 CF3M + lining
12	Bonnet	A216 WCB + lining	A351 CF8 7 A351 CF8M + lining	A351 CF3 / A351 CF3M + lining

DIMENSIONS AND WEIGHTS - PN10

DN	L	D	D1	D2	Z-d	f	b	kg
15	132	95	65	45	4-14	2	14	3,5
20	142	105	75	55	4-14	2	14	4
25	150	115	85	65	4-14	2	14	5,5
32	169	140	100	78	4-18	3	16	7
40	180	150	110	85	4-18	3	16	9
50	200	165	125	100	4-18	3	16	15,5
65	220	185	145	120	4-18	3	18	19,5
80	250	200	160	135	8-18	3	20	30
100	280	220	180	155	8-18	3	20	40
125	320	250	210	185	8-18	3	22	56
150	360	285	240	210	8-23	3	24	72

BALL VALVES

KHY-2F-F-VIII/FEP/FEP

Lined ball valve with flanges, PN10, 16, 25



DIMENSIONS AND WEIGHTS - PN16

DN	L	D	D1	D2	Z-d	f	b	kg
15	132	95	65	45	4-14	2	15	3,5
20	142	105	75	55	4-14	2	16	4
25	150	115	85	65	4-14	2	16	5,5
32	165	140	100	78	4-18	3	16	7
40	180	150	110	85	4-18	3	17	9
50	200	165	125	100	4-18	3	18	15,5
65	220	185	145	120	4-18	3	20	19,5
80	250	200	160	135	8-18	3	22	30
100	280	220	180	155	8-18	3	24	40
125	320	250	210	185	8-18	3	26	57
150	360	285	240	210	8-23	3	28	73,5

DIMENSIONS AND WEIGHTS - PN25

DN	L	D	D1	D2	Z-d	f	b	kg
15	140	95	65	45	4-14	2	16	3,5
20	152	105	75	55	4-14	2	16	4
25	165	115	85	65	4-14	2	16	5,5
32	178	140	100	78	4-18	3	18	7
40	190	150	110	85	4-18	3	18	9
50	216	165	125	100	4-18	3	20	15,5
65	241	185	145	120	8-18	3	22	19,5
80	283	200	160	135	8-18	3	22	30
100	305	235	190	160	8-23	3	24	40
125	381	270	220	188	8-25	3	28	56
150	403	300	250	218	8-25	3	30	72

BALL VALVES

KHY-2F-F-VIII/FEP/FEP

Lined ball valve with flanges, PN10, 16, 25

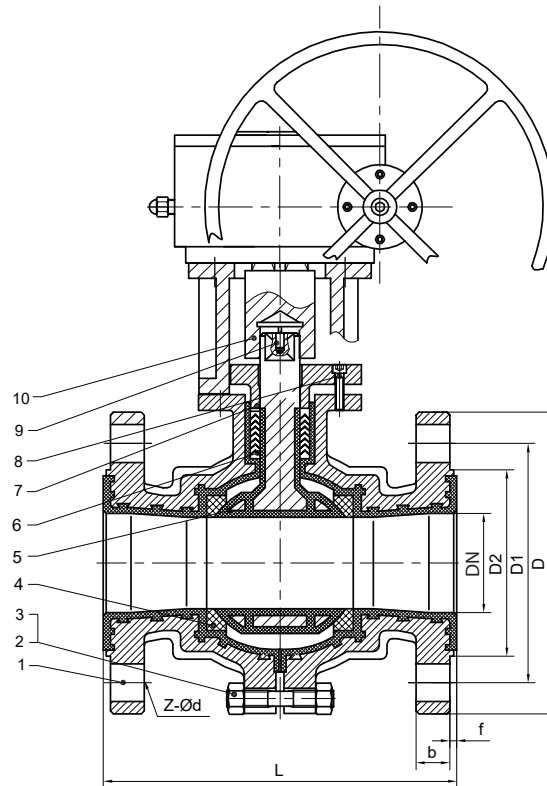

DIMENSIONS AND WEIGHTS - PN10

DN	L	D	D1	D2	Z-d	f	b	kg
200	400	340	295	265	8-23	3	26	72

DIMENSIONS AND WEIGHTS - PN16

DN	L	D	D1	D2	Z-d	f	b	kg
200	400	340	295	265	12-23	3	30	121

DIMENSIONS AND WEIGHTS - PN25

DN	L	D	D1	D2	Z-d	f	b	kg
200	419	360	310	278	12-25	3	34	119